

## MODEL 1089WA ALUMINUM THERMOCOUPLE HEAD FOR LARGE DEVICES

- DIE-CAST ALUMINUM CONSTRUCTION
- BLUE EPOXY COATED
- ACCOMODATES LARGE DEVICES 70MM (2.7")
- WIDE RANGE OF ACCESSORIES
- PROVISION FOR CUSTOM SS NAME PLATES
- WIDE SELECTION OF CONDUIT SIZES



### Specifications

#### Material of Construction:

Die-Cast Aluminum

#### Certification:

None

#### Connections

From 1/2" NPT, 3/4" NPT, 1/2" BSP, 3/4" BSP M20x1.5

#### Mounting Holes

See attached drawing

#### Surface Finishing

Blue Epoxy Coated

#### "O" Ring

Buna "N"

#### Weight

1.2lbs (550g)

#### Accessories

SS Ball Chain, Terminal Block(Ceramic/Bakelite, Optional)  
Custom Designed name plate

### Dimensions (in mm)

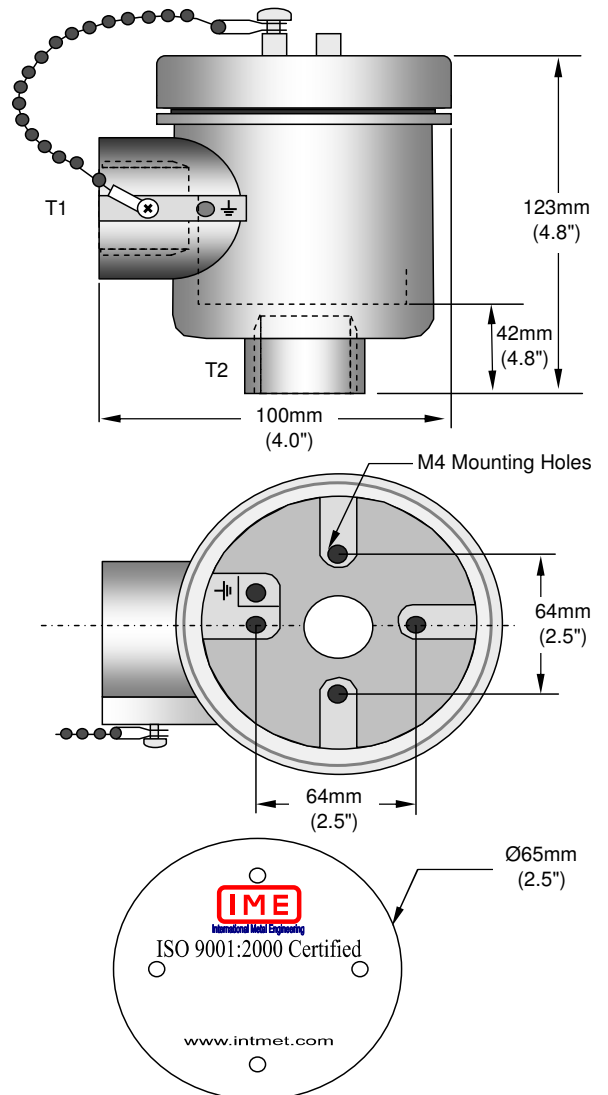

### Ordering Information

Model	Description	
1089WA	Aluminum Housing, General Purpose, Blue Epoxy Coated, Solid cover	
1089WG	Aluminum Housing, General Purpose, Blue Epoxy Coated, Cover with Tempered Glass Window	
	Code	Connection
		T1 T2
	01	T1=3/4" NPT T2=1/2"NPT
	02	T1=1/2" NPT T2=1/2"NPT
	04	T1=3/4" BSP T2=1/2"BSP
	05	T1=M20X1.5 T2=1/2"BSP
	08	T1=M20X1.5 T2=1/2"NPT
	33	T1=3/4" NPT T2=3/4" NPT
	XX	Specify Specify
1089WA	01	Typical Model Number

TYPICAL SS NAMEPLATE SUPPLIED BBY IME BASED ON ARTWORK PROVIDED BY CUSTOMER